

Metro RISER METAL
1X4 BATTENS
Fascia Cross-Section detail

Metro Roof Products
 3093 'A' Industry St., Oceanside
 CA USA 92054
www.metroroofs.com

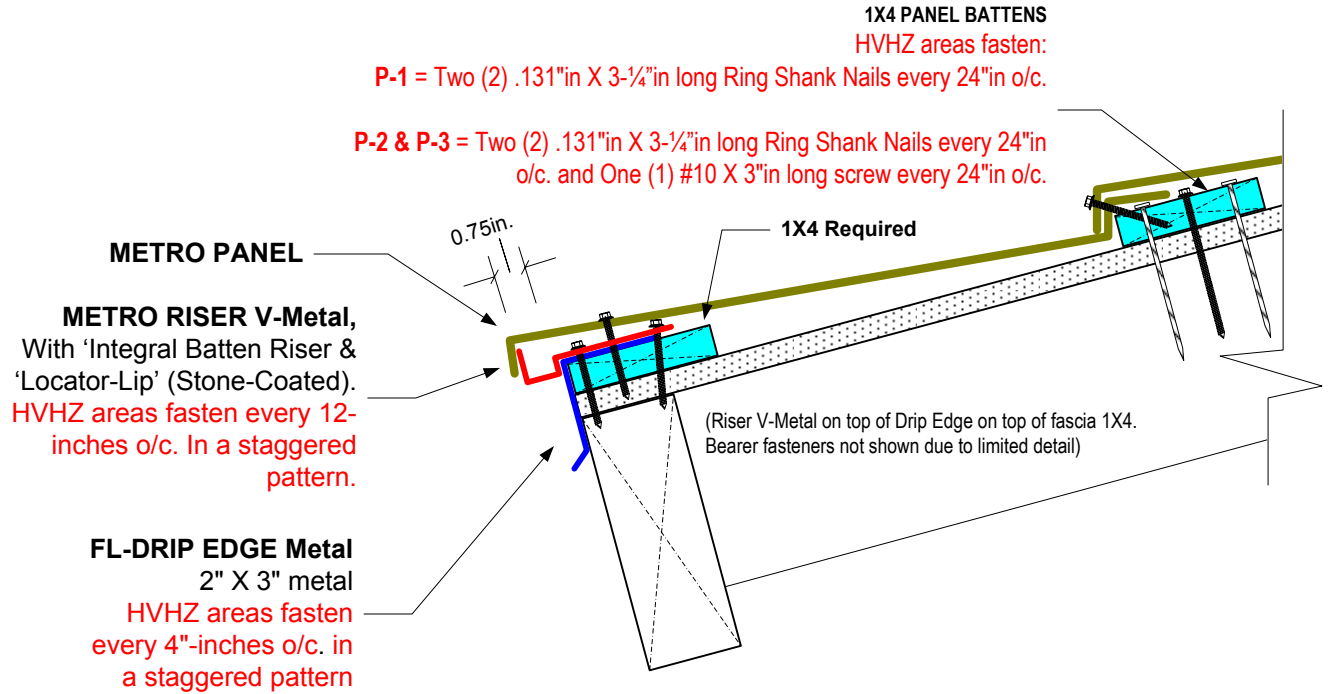

HVHZ - DRIP EDGE DETAILS

- Vertical Flange: (Vertical face of fascia) - Min., 1-1/2" inches
- Horizontal Flange: (Up Roof Slope) - Min., 2" Inches
- Over-Lap: (End to End laps) - Min., 4" inches

FASTENING:

- Nails: - Min., #12 ga. Pan or Flat head Annular Ring Shank nails
- Spacing: - Min., spacing of 4" Inches O/C in a staggered pattern.

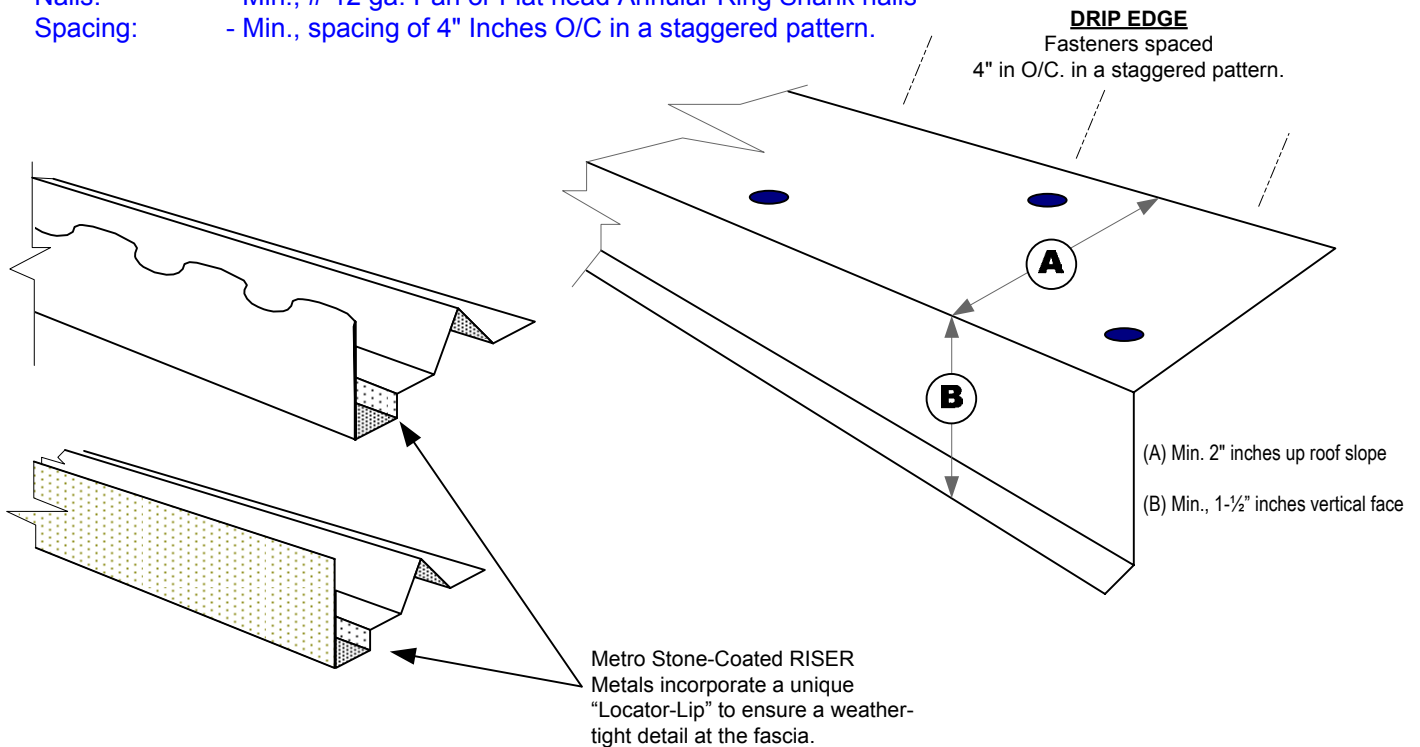

HVHZ = High Velocity Hurricane Zone

Refer to Metro HVHZ Florida Approvals FL-698, FL-6710 for PANEL fasteners & fastening pattern details.

DATE	REVISED	FILENAME
3-13-06	4/2/2007	CITY OF TAMARAC FL 1X4OLDRISERDETAIL.VSD